

The World's Most Trusted Industrial Torque and Tension Systems

jGun™ Dual Speed Plus

The Speed and Conveniences of an Impact Wrench
without the Noise, Vibration and Load Variation

- High Speed Rundown & Final Torque
- Maximum torque requires only 90 psi
- Extensions available for Job Specific Applications
- Made from Lightweight High-Strength Aluminum Alloy
- Precision Gearing Produces Constant, Calibrated Power
- Eliminates the Need to use Impact Guns for Pre-Torquing
- Highest Power-to-Weight Ratio of any Comparable Product
- Compatible with our HYTORC Washer™ and HYTORC Nut™
Stretch-to-Load Fastening Systems for maximum bolt load accuracy
- Splined Reaction Area Allows for the Use of Custom Reaction Fixtures



This safety mechanism drastically reduces operator error. The lever must be depressed while pulling the trigger, ensuring operator keeps hands away from pinch points.

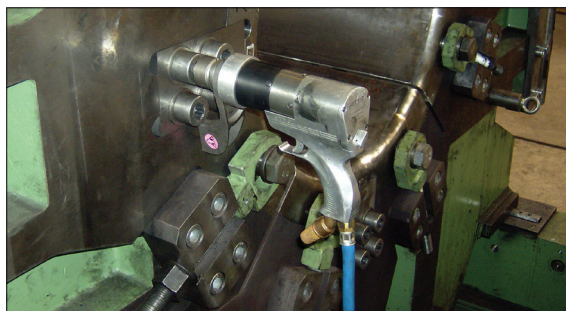

24 Hour SERVICE

888-GUN-2-GUN

www.torquegun.com

THE
TORQUE GUN™
COMPANY

120 WESLEY ST., SO. HACKENSACK NJ 07606

ACCESSORIES



JOB SPECIFIC EXTENSIONS

We will work together with you to develop a faster, easier or safer solution for any bolting issues you may have.



FRL UNIT

Filter, Regulator and Lubrication Unit. For use with all torque guns. Optional Silencer Unit to reduce operational noise by 35%, down to a very low 70-75 Db.



OFFSET LINKS

For limited clearance. jGun accessories are designed with the highest quality standards.



DIMENSIONAL DATA

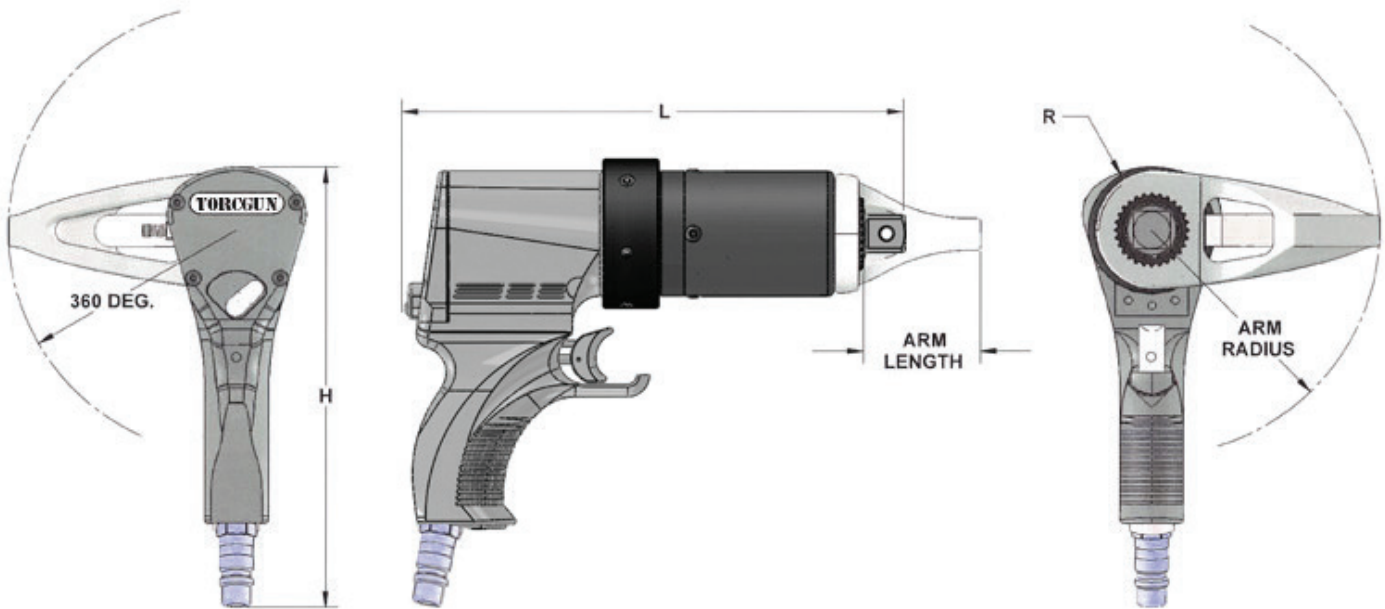

	Torque Range	Drive	Bolt Sizes	H	L	R	Arm Length	Arm Radius	Rundown RPM	Final Torque RPM	Weight w/o Arm	Weight w/ Arm
Model	Ft. Lbs./Nm			Inches/cm							Lbs./Kg	
J-A.5-AP	195-500/264-678	¾"	½" to 1"	7.40/18.80	10.03/25.47	1.25/3.18	2.40/6.09	4.48/11.38	420	24	9.04/4.10	10.25/4.6
J-A1-AP	320-1285/434-1742	¾"	7/8" to 1 3/8"	8.92/22.66	10.76/27.33	1.25/3.18	2.40/6.09	4.48/11.38	120	6.5	9.7/4.40	10.9/4.9
J-A3-AP	915-3305/1240-4481	1"	1 ¼" to 1 7/8"	7.34/18.60	12.35/31.37	1.81/4.60	3.83/9.73	5.85/14.68	35	2	12.0/5.4	15.35/7.0
J-A5-AP	750-4500/1017-6101	1 ½"	1 13/16" to 3 1/8"	8.42/21.39	14.46/36.73	4.48/11.38	TBD	TBD	38	2.5	22.5/10.2	28.75/13.4
J-A8-AP	1300-8000/1763-10846	1 ½"	1 13/16" to 3 1/8"	8.46/21.49	15.38/39.10	4.56/11.58	TBD	TBD	35	1.5	28/12.7	36.5/16.6